

PAPER TOWEL DISPENSER WP170



298 x 148 x 310 mm

approx. 500 paper towels

- Paper towel dispenser in robust, germ-reducing and easy-care stainless steel (AISI 304).
- Suitable for flush horizontal under-counter mounting.
- All-stainless steel housing; all corners fully welded, visible surfaces satin finished and brushed. Further available surfaces: see below.
- With deep-drawn paper removal opening for easy paper removal.
- Designed for approx. 500 standard paper towels in zigzag- or c-fold. Paper size (folded): 240-250 mm x 100-115 mm. Accessible for refilling through lockable drawer.
- Keyed alike cylinder lock in corrosion-resistant zinc die-casting.
- Wear parts can be replaced as modules.
- Installation dimensions: 300 x 150 mm
- Mounting: With screws on the inside.
- Delivery includes fixing material and one pack of paper towels.
- Weight, including single package: 3.1 kg



Suggested text for specifications:

Paper towel dispenser in stainless steel (AISI 304) for flush horizontal under-counter mounting. All-stainless steel housing; all corners fully welded, visible surfaces satin finished and brushed. With deep-drawn paper removal opening, filling quantity approx. 500 paper towels. Accessible for refilling through lockable drawer. Keyed alike cylinder lock in corrosion-resistant zinc die-casting. Delivery includes fixing material and one pack of paper towels.

Dimensions: 298 x 148 x 310 mm

Article No. WP170

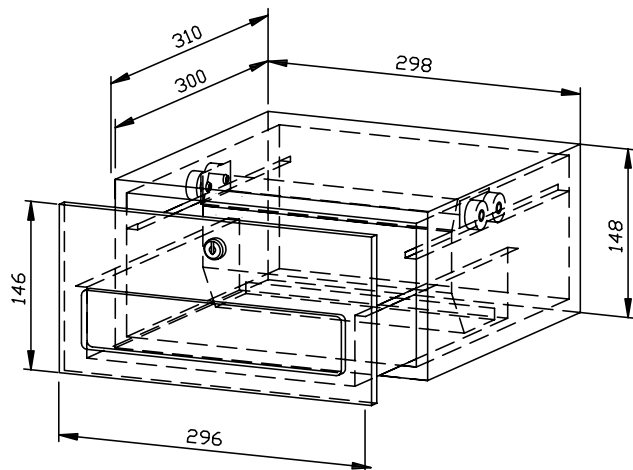

Available surfaces	ID No.
satin finished (standard)	727 408
highly polished	731 408
(coloured) plastic powder-coating	728 128

Ernst Wagner GmbH & Co. KG

Ernst-Abbe-Straße 21 · D-72770 Reutlingen · Tel.: +49712151539-0 · Fax: -20
info@wagner-ewar.de · www.wagner-ewar.de

WAGNER
E W A R